

Mechanical Backup Valves

Mechanical Backup Valves automatically maintain a pre-set water level near the bottom of a rainwater tank when there is insufficient rainfall to meet the water demand. As the water level drops, a weighted float slides down a long cord until it reaches a stop at the end. When the water level continues to drop, the weight of the float pulls the valve arm, allowing the backup water supply to flow into the tank. The water level rises and lifts the float, causing the valve arm to rise and shut off the water flow.

Two options are available: a 1/2" low-flow valve and a 1" high-flow valve. At typical municipal water pressures, the 1/2" valve supplies less than 4 gpm, so it is recommended for small-scale systems where the rate of water use is relatively low. In contrast, at typical municipal water pressures the 1" valve supplies more than 60 gpm which is sufficient to match the extraction rate of large rainwater harvesting systems.

All parts are corrosion free plastics and stainless steel for trouble-free performance. Other features include extra-long mounting stems to accommodate thick-wall tanks, an integral mounting nut and sealing gasket that eliminate the need for a tank bulkhead, and a blocking device that enables the valve to be locked in the closed position. Internal check valves are also standard, but to prevent cross-contamination the valves outlet should be located several inches above the high water level of the tank.



OPERATION

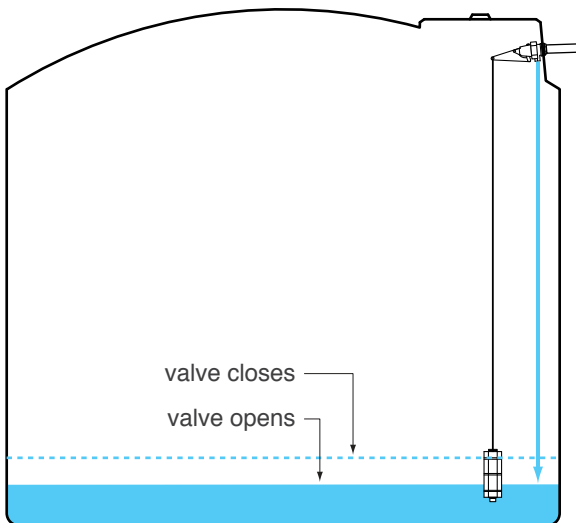

During dry periods, the water level drops until the float reaches the cord stop and opens the backup valve. The water rises a few inches, lifting the float and closing the valve.

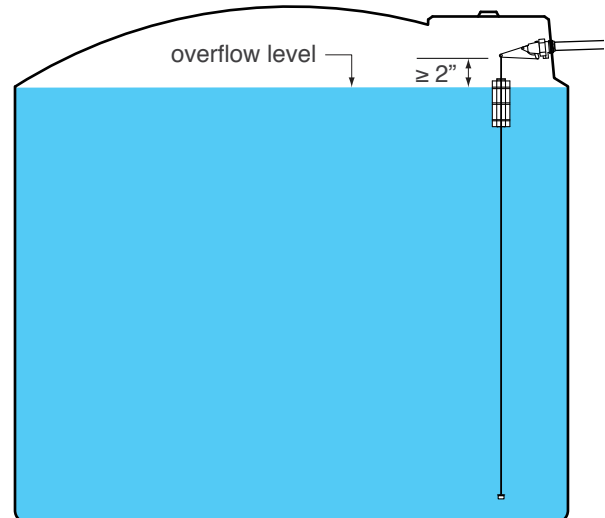

During wet period, rainwater fills the tank, the float ascends the cord, and the valve remains closed. To prevent backflow, the valve outlet must be 2"+ above the tank high water level.

DIMENSIONS

Note: Connect pipe to female-threaded plastic adapters screwed onto mounting stem.

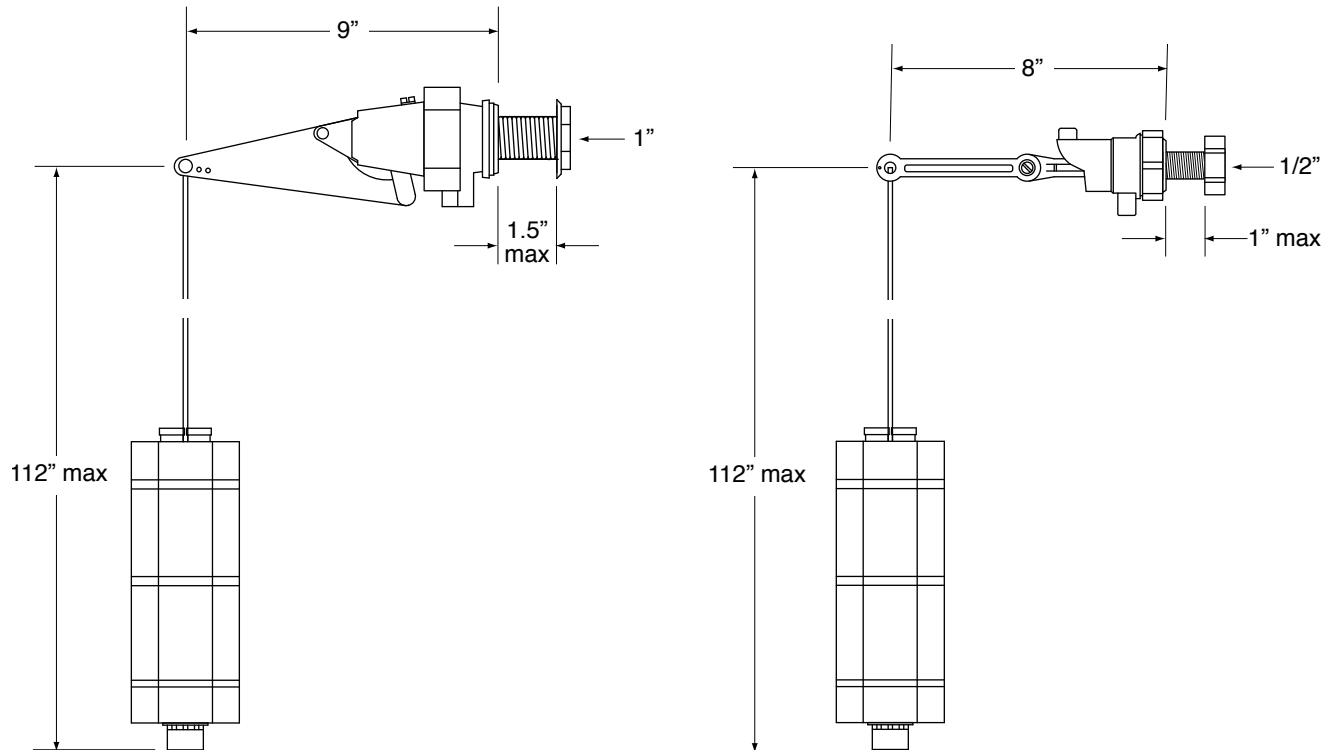

HYDRAULIC PERFORMANCE

Note: The 1/2" low-flow valve is rated for pressures of 0-150 psi and the high-flow valve is rated for 5-150 psi.

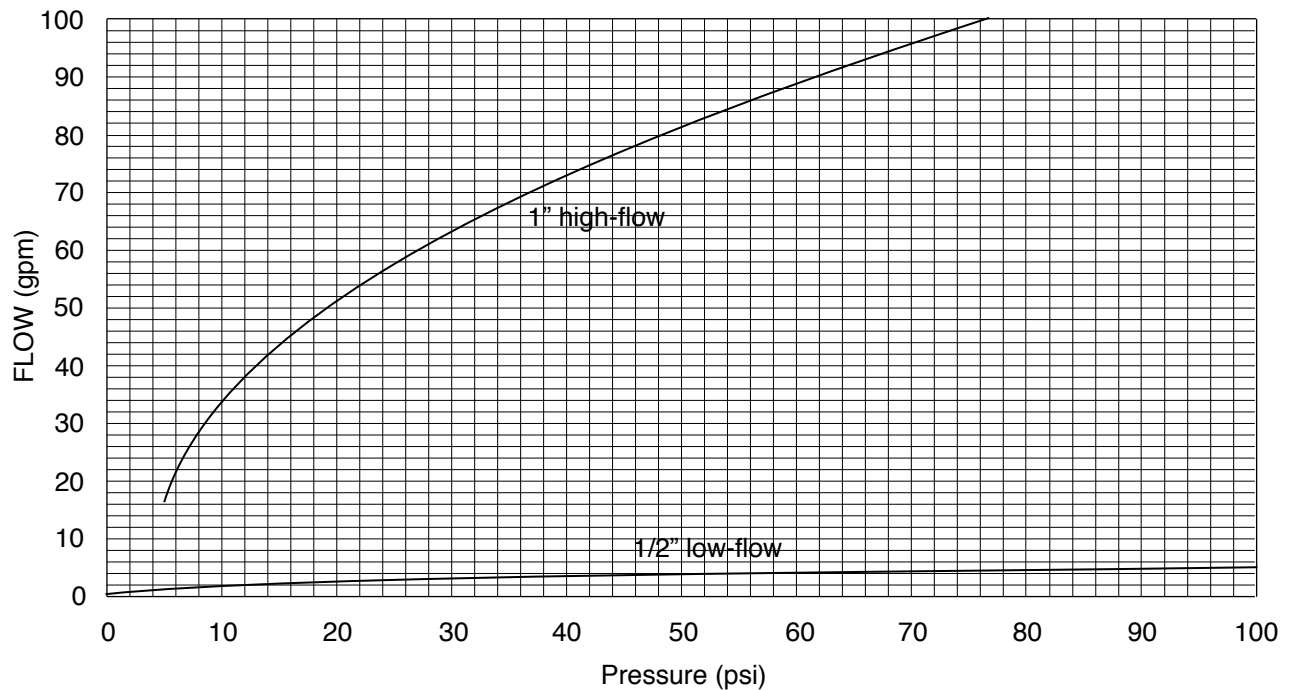

INSTALLATION

In the illustration below, a Mechanical Backup Valve, fed by a public water supply, maintains a water level of approximately 8" to 12" at the bottom of a surface storage tank when rainwater is not available. The underground Amphibian pump supplies either rainwater or backup water without the risk of dry-running. The mounting height of the MiniCascade prefilter is critical because it defines high-water level of the tank and eliminates the need for a separate overflow: when the tank water level reaches the weir level, roof water simply passes through the filter into the overflow pipe. To prevent cross-contamination the outlet of the backup valve must be at least several inches above the high water level defined by the prefilter, in this case the top of the cylindrical tank body.

